

Installation

The following information is intended for use by suitably qualified technical staff. Please pay attention to the following warnings.

WARNING

- **Installation of the didBOX must be carried out by a suitably qualified technician.**
- **This information is a guide to typical machine fitting. The installer must ensure that the installation complies with applicable safety and other standards.**
- **Disconnect all electrical power (e.g. batteries, charges, external supplies) before installation.**
- **Ensure machine operation is inhibited during installation.**
- **Follow all machine manufacturers' recommendations and safety warnings.**
- **Read this installation guide carefully before proceeding.**

Mounting the Dash Reader and Control Box

To fit the didBOX, a suitable mounting position should be selected for the dash mounted button reader and the control box. The dash reader must be easily accessible to the operator each time the machine is started. This may typically be close to the starting switch on the machine dash board.

The control box must be mounted in a concealed position, within approximately 300mm of the button reader and protected from direct exposure to weather.

Drill a 20mm hole to mount the dash reader. Disconnect the reader from the control box noting the coloured wire connections. Remove the reader back nut. Feed the reader cable through the hole from the front then fit the back nut finger tight, in place. The LED indicator on the reader must be at the top (i.e. in the 12 o'clock position).

NB: Secure the back of the reader lead in place (e.g. with a cable tie) to ensure that the lead cannot be pulled from the back of the reader head.

Install the control box by drilling 2 holes and use the 2 bolts provided. Reconnect the dash reader connections. If necessary, refer to the diagram overleaf to ensure correct wiring.

Electrical Connections and Wiring

As a minimum, the didBOX requires connection to the vehicle power supply, dash mounted reader and an electrical relay to inhibit vehicle operation until after successful log on.

The standard unit is designed to operate between 8-48v DC, making it suitable for direct connection to 12v, 24v or 48v battery systems. On higher voltage systems a voltage regulator must be used to drop the voltage to 12v or 24v nominal.

The 12v/24v/48v supply must be from a circuit on the vehicle which is switched on when the operator switches on the vehicle preparing to start/use the machine.

The supply must also be switched off when the vehicle is not in use. Switching off this supply is used to detect operator log on and log off activity.

Power to the didBOX should be protected by a fuse or circuit breaker. The maximum power consumption of the didBOX is 1 amp.

Vehicle Inhibit Connection and Wiring

On engine driven machines, the didBOX is normally connected to interrupt the switched signal to operate the starter motor, this only goes live after a successful log on by an operator.

The control output from the didBOX is low power and therefore requires a relay or similar, A typical circuit is shown below.

Typical Wiring Diagram LPG/Diesel

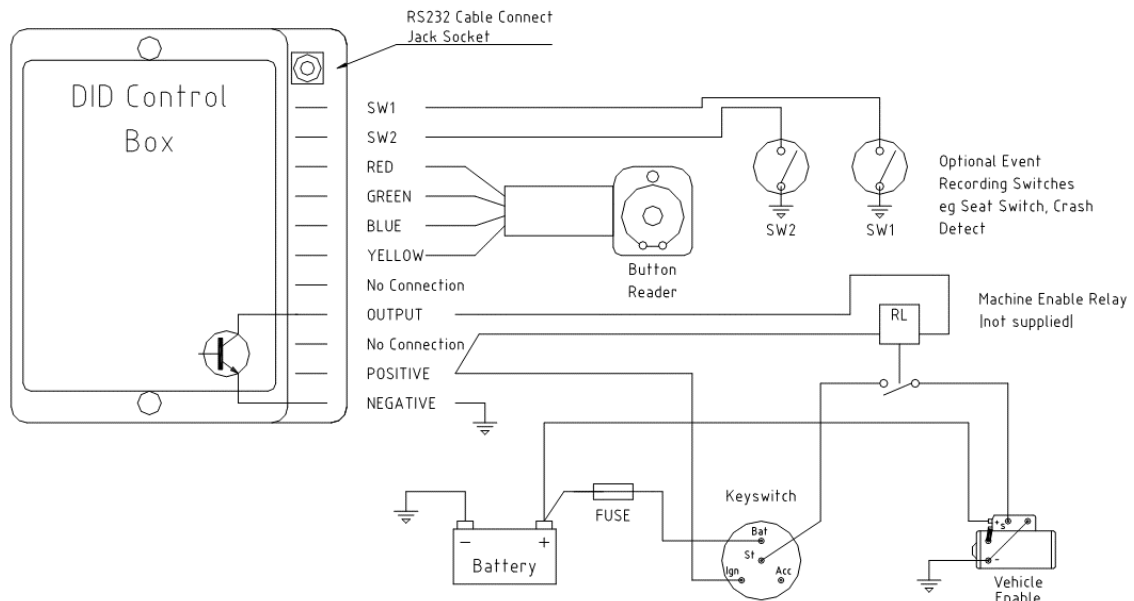

After completion, switch on the vehicle and the LED on the button reader will light red.

The black key fobs attached to the didBOX reader lead when it is shipped will be already authorised to start the didBOX.

These keyfobs can be used to test that the system is accepting authorised keyfobs during the installation process and prior to the systems being programmed for normal use.

Collision Sensor Mounting and Wiring

The mounting of the sensor is **very important**. Find a suitable position on the vehicle, preferably along the centre line of the machine and approximately 425 mm up from ground level.

(this should coincide with the centre line of the vehicle axle).

Secure using 2 M4 screws through the mounting holes. In some cases a 90° bracket may be required to assist the mounting position. (supplied with the unit)

The wires are clearly marked. Brown is continuous live feed 12-48v DC (not switched). Blue is 0 V

The signal wires are. Yellow/Green 2g, Grey 5G and Black 10G these are connected to SW1 terminal on the didBOX as per the wiring diagram.

Operation & Settings

In normal operations the sensor will be wired to the didBOX to monitor 2 G Low level but can be wired to any combination of two out of the three levels.

Once the sensor has been wired in, it will need to be set up. This is carried out by placing the supervisor key into the switch assembly next to the LED.

First entry will clear the LED or Beacon

Second entry the LED will blink Green 2G set (Low)

Third Entry the LED will blink Orange 5g set (Medium)

Fourth Entry the LED will blink Red.10g set (High)

The sensor is now set and ready to monitor. Once the sensor has been triggered and indicated by the LED. Only if a greater shock level is received will the LED change indication. The LED will continue to show the greatest shock level received until the unit is reset.

If a beacon or horn is fitted

The external beacon or horn will light/sound after the first shock has been received and will remain on (10s on/ 10s off) until the unit is reset.

Shock level Low : Green LED and one beacon pulse

Shock level Medium : Orange LED pulses and two beacon pulses

Shock level High : Red LED pulses and three beacon pulses

NB

If you would like to monitor the other levels available, the connections on the didBOX will need to be swapped over.

EG 2 and 5G. Green/Yellow on SW1 and Grey 5G on SW2.

If the unit is set to 5G and you only wish to monitor 5 or 10G the LED will only show the level or higher that has been triggered. The beacon will light on all levels

Voltage outputs Collision sensor

The voltage output will drop to 0V for 10 seconds upon the application of shock. The 12 voltage output will always be active regardless of beacon settings.

Technical Specification

Control Box	
Operating voltage	8-48v DC continuous
Reverse voltage	Protected
Current max	500ma
Dimensions	H85mm x W105mm x D35mm
Fixing holes	2x5mm diameter 95mm apart
Operating temperature	0C to +60C
Enclosure environment protection	(Protect terminations from direct exposure to weather)

Dashboard Mounted Reader	
Fixing hole	20mm diameter
Operating temperature	0C to +60C
Installed environmental protection (from front)	IP65
Relative humidity	95% at +60C
Cable length	400mm max

Wand Reader for connection to PC Serial RS232 COMM port	
Dimensions	H125mm x W60mm x D30mm
Operating temperature	0C to +60C
Enclosure environmental protection	IP44 (for indoor use)
Software	Win95/98/2000/XP/Vista

Operator and Administrator Keyfobs	
Weight	3.3 grammes (typical, varies with type)
Operating temperature	-40C to +70C
Humidity	90% RH at +50C
Expected service life	10 years at +25C
Safety	Meets UL#913 (4 th edit); Intrinsically Safe Apparatus. Approved under Entity Concept or use in Class 1, Division 1, Group A, B, C and D locations